

Lecture 5

Biot-Savart law, Conductive Media Interface, Instantaneous Poynting's Theorem

Biot-Savart law, like Ampere's law was experimentally determined in around 1820 and it is discussed in a number of textbooks [31, 32, 48]. This is the cumulative work of Ampere, Oersted, Biot, and Savart. At this stage of the course, one has the mathematical tool to derive this law from Ampere's law and Gauss's law for magnetostatics. In addition, we will study the boundary conditions at conductive media interfaces, and introduce the instantaneous Poynting's theorem.

5.1 Derivation of Biot-Savart Law

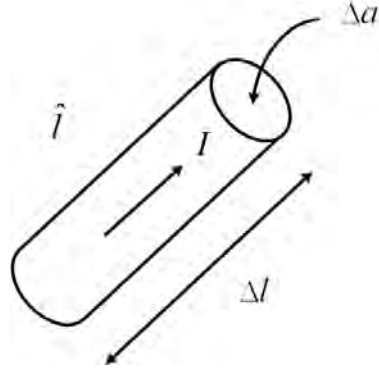

Figure 5.1: A current element used to illustrate the derivation of Biot-Savart law. The current element generates a magnetic field due to Ampere's law in the static limit. This law was established experimentally, but here, we will derive this law based on our mathematical knowledge so far.

From Gauss' law and Ampere's law in the static limit, and using the definition of the Green's function, we have derived that

$$\mathbf{A}(\mathbf{r}) = \frac{\mu}{4\pi} \iiint_V \frac{\mathbf{J}(\mathbf{r}')}{R} dV' \quad (5.1.1)$$

where $R = |\mathbf{r} - \mathbf{r}'|$. When the current element is small, and is carried by a wire of cross sectional area Δa as shown in Figure 5.1, we can approximate the integrand as

$$\mathbf{J}(\mathbf{r}') dV' \approx \mathbf{J}(\mathbf{r}') \Delta V' = \underbrace{(\Delta a) \Delta l}_{\Delta V'} \underbrace{\hat{l} I / \Delta a}_{\mathbf{J}(\mathbf{r}')} \quad (5.1.2)$$

In the above, $\Delta V' = (\Delta a) \Delta l$ and $\hat{l} I / \Delta a = \mathbf{J}(\mathbf{r}')$ since \mathbf{J} has the unit of amperes/m². Here, \hat{l} is a unit vector pointing in the direction of the current flow. Hence, we can let the current element be

$$\mathbf{J}(\mathbf{r}') \Delta V' = I \Delta \mathbf{l}' \quad (5.1.3)$$

where the vector $\Delta \mathbf{l}' = \Delta l \hat{l}$, and ' indicates that it is located at \mathbf{r}' . Therefore, the incremental vector potential due to an incremental current element $\mathbf{J}(\mathbf{r}') \Delta V'$ is

$$\Delta \mathbf{A}(\mathbf{r}) = \frac{\mu}{4\pi} \left(\frac{\mathbf{J}(\mathbf{r}') \Delta V'}{R} \right) = \frac{\mu}{4\pi} \frac{I \Delta \mathbf{l}'}{R} \quad (5.1.4)$$

Since $\mathbf{B} = \nabla \times \mathbf{A}$, we derive that the incremental \mathbf{B} flux, $\Delta\mathbf{B}$ due to the incremental current $I\Delta\mathbf{l}'$ is

$$\Delta\mathbf{B} = \nabla \times \Delta\mathbf{A}(\mathbf{r}) = \frac{\mu I}{4\pi} \nabla \times \frac{\Delta\mathbf{l}'}{R} = \frac{-\mu I}{4\pi} \Delta\mathbf{l}' \times \nabla \frac{1}{R} \quad (5.1.5)$$

where we have made use of the fact that $\nabla \times \mathbf{a}f(\mathbf{r}) = -\mathbf{a} \times \nabla f(\mathbf{r})$ when \mathbf{a} is a constant vector. The above can be simplified further making use of the fact that¹

$$\nabla \frac{1}{R} = -\frac{1}{R^2} \hat{R} \quad (5.1.6)$$

where \hat{R} is a unit vector pointing in the $\mathbf{r} - \mathbf{r}'$ direction. We have also made use of the fact that $R = \sqrt{(x - x')^2 + (y - y')^2 + (z - z')^2}$. Consequently, assuming that the incremental length becomes infinitesimally small, or $\Delta\mathbf{l} \rightarrow \mathbf{dl}$, we have, after using (5.1.6) in (5.1.5), that

$$\begin{aligned} \mathbf{dB} &= \frac{\mu I}{4\pi} \mathbf{dl}' \times \frac{1}{R^2} \hat{R} \\ &= \frac{\mu I \mathbf{dl}' \times \hat{R}}{4\pi R^2} \end{aligned} \quad (5.1.7)$$

Since $\mathbf{B} = \mu\mathbf{H}$, we have

$$\mathbf{dH} = \frac{I \mathbf{dl}' \times \hat{R}}{4\pi R^2} \quad (5.1.8)$$

or

$$\mathbf{H}(\mathbf{r}) = \int \frac{I(\mathbf{r}') \mathbf{dl}' \times \hat{R}}{4\pi R^2} \quad (5.1.9)$$

which is Biot-Savart law, first determined experimentally, now derived using electromagnetic field theory.

¹This is best done by expressing the ∇ operator in spherical coordinates.

5.2 Shielding by Conductive Media

5.2.1 Boundary Conditions—Conductive Media Case

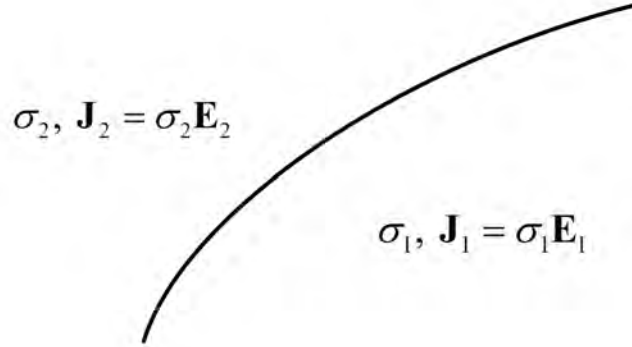

Figure 5.2: The schematics for deriving the boundary condition for the current density \mathbf{J} at the interface of two conductive media.

In a conductive medium, $\mathbf{J} = \sigma \mathbf{E}$, which is just a statement of Ohm's law. From the current continuity equation, which is derivable from Ampere's law and Gauss' law for electric flux, one gets

$$\nabla \cdot \mathbf{J} = -\frac{\partial \rho}{\partial t} \quad (5.2.1)$$

If the right-hand side is everywhere finite, it will not induce a jump discontinuity in the current. Moreover, it is zero for static limit. Hence, just like the Gauss's law case, the above implies that the normal component of the current J_n is continuous, or that $J_{1n} = J_{2n}$ in the static limit. In other words,

$$\hat{n} \cdot (\mathbf{J}_2 - \mathbf{J}_1) = 0 \quad (5.2.2)$$

Hence, using $\mathbf{J} = \sigma \mathbf{E}$, we have

$$\sigma_2 E_{2n} - \sigma_1 E_{1n} = 0 \quad (5.2.3)$$

The above has to be always true in the static limit irrespective of the values of σ_1 and σ_2 . But Gauss's law implies the boundary condition that

$$\varepsilon_2 E_{2n} - \varepsilon_1 E_{1n} = \rho_s \quad (5.2.4)$$

The above equation is incompatible with (5.2.3) unless $\rho_s \neq 0$. Hence, surface charge density or charge accumulation is necessary at the interface, unless $\sigma_2/\sigma_1 = \varepsilon_2/\varepsilon_1$. This is found in semiconductor materials which are both conductive and having a permittivity: interfacial charges appear at the interface of two semi-conductor materials.

5.2.2 Electric Field Inside a Conductor

The electric field inside a perfect electric conductor (PEC) has to be zero by the explanation as follows. If medium 1 is a perfect electric conductor, then $\sigma \rightarrow \infty$ but $\mathbf{J}_1 = \sigma \mathbf{E}_1$. An infinitesimal \mathbf{E}_1 will give rise to an infinite current \mathbf{J}_1 . To avoid this ludicrous situation, \mathbf{E}_1 has to be 0. This implies that $\mathbf{D}_1 = 0$ as well.

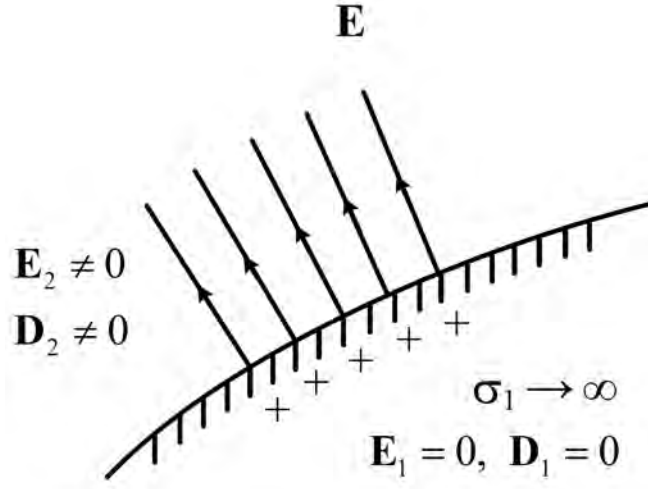

Figure 5.3: The behavior of the electric field and electric flux at the interface of a perfect electric conductor and free space (or air).

Since tangential \mathbf{E} is continuous, from Faraday's law, it is still true that

$$E_{2t} = E_{1t} = 0 \quad (5.2.5)$$

or $\hat{n} \times \mathbf{E} = 0$. But since

$$\hat{n} \cdot (\mathbf{D}_2 - \mathbf{D}_1) = \rho_s \quad (5.2.6)$$

and that $\mathbf{D}_1 = 0$, then

$$\hat{n} \cdot \mathbf{D}_2 = \rho_s \quad (5.2.7)$$

So surface charge density has to be nonzero at a PEC/air interface. Moreover, normal $\mathbf{D}_2 \neq 0$, tangential $\mathbf{E}_2 = 0$: Thus the \mathbf{E} and \mathbf{D} have to be normal to the PEC surface. The sketch of the electric field in the vicinity of a perfect electric conducting (PEC) surface is shown in Figure 5.3.

The above argument for zero electric field inside a perfect conductor is true for electrodynamic problems. However, one does not need the above argument regarding the shielding of the static electric field from a conducting region. In the situation of the two conducting

objects example below, as long as the electric fields are non-zero in the objects, currents will keep flowing. They will flow until the charges in the two objects orient themselves so that electric current cannot flow anymore. This happens when the charges produce internal fields that cancel each other giving rise to zero field inside the two objects. Faraday's law still applies which means that tangential \mathbf{E} field has to be continuous. Therefore, the boundary condition that the fields have to be normal to the conducting object surface is still true for electrostatics. A sketch of the electric field between two conducting spheres is show in Figure 5.4.

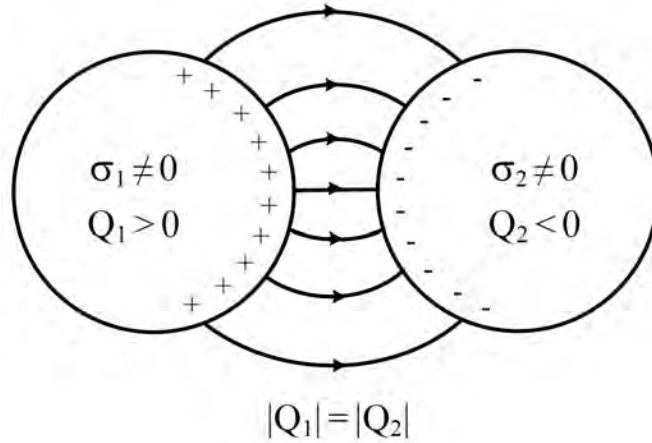

Figure 5.4: The behavior of the electric field and flux outside two conductors in the static limit. The two conductors need not be PEC, and yet, the fields are normal to the interface.

5.2.3 Magnetic Field Inside a Conductor

We have seen that for a finite conductor, as long as $\sigma \neq 0$, the charges will re-orient themselves until the electric field is expelled from the conductor; otherwise, the current will keep flowing until $\mathbf{E} = 0$ or $\partial_t \mathbf{E} = 0$. In a word, static \mathbf{E} is zero inside a conductor.

But there are no magnetic charges nor magnetic conductors in this world. Thus this physical phenomenon does not happen for magnetic field: In other words, static magnetic field cannot be expelled from an electric conductor. However, a magnetic field can be expelled from a perfect conductor or a superconductor. You can only fully understand this physical phenomenon if we study the time-varying form of Maxwell's equations.

In a perfect conductor where $\sigma \rightarrow \infty$, it is unstable for the magnetic field \mathbf{B} to be nonzero. As time varying magnetic field gives rise to an electric field by the time-varying form of Faraday's law, a small time variation of the \mathbf{B} field will give rise to infinite current flow in a perfect conductor. Therefore to avoid this ludicrous situation, and to be stable, $\mathbf{B} = 0$ in a perfect conductor or a superconductor.

So if medium 1 is a perfect electric conductor (PEC), then $\mathbf{B}_1 = \mathbf{H}_1 = 0$. The boundary condition for magnetic field from Ampere's law

$$\hat{n} \times (\mathbf{H}_2 - \mathbf{H}_1) = \hat{n} \times \mathbf{H}_2 = \mathbf{J}_s \tag{5.2.8}$$

which is the jump condition for the magnetic field. In other words, a surface current \mathbf{J}_s has to flow at the surface of a PEC in order to support the jump discontinuity in the tangential component of the magnetic field. From Gauss's law, $\hat{n} \cdot \mathbf{B}$ is always continuous at an interface because of the absence of magnetic charges. The magnetic flux \mathbf{B}_1 is expelled from the perfect conductor making $\hat{n} \cdot \mathbf{B}_1 = 0$ zero both inside and outside the PEC (due to the continuity of normal \mathbf{B} at an interface). And hence, there is no normal component of the \mathbf{B}_1 field at the interface. Therefore, the boundary condition for \mathbf{B}_2 becomes, for a PEC,

$$\hat{n} \cdot \mathbf{B}_2 = 0 \tag{5.2.9}$$

The \mathbf{B} field in the vicinity of a perfect conductor surface is as shown in Figure 5.5.

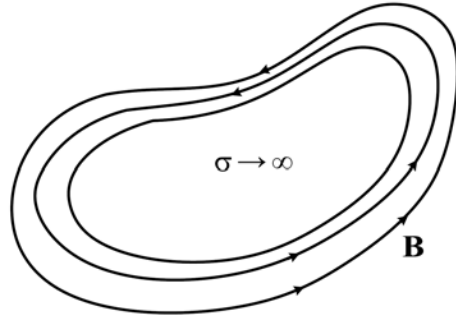

Figure 5.5: Sketch of the magnetic flux \mathbf{B} around a perfect electric conductor. It is seen that $\hat{n} \cdot \mathbf{B} = 0$ at the surface of the perfect conductor.

When a superconductor cube is placed next to a static magnetic field near a permanent magnet, eddy current will be induced on the superconductor. The eddy current will expel the static magnetic field from the permanent magnet, or in a word, it will produce a magnetic dipole on the superconducting cube that repels the static magnetic field. Since these two magnetic dipoles are of opposite polarity, they repel each other, and cause the superconducting cube to levitate on the static magnetic field as shown in Figure 5.6.

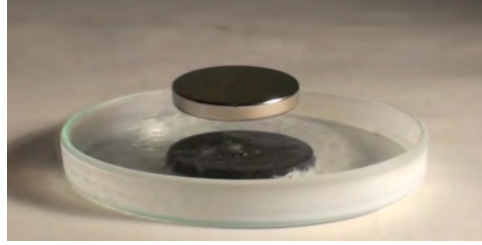

Figure 5.6: Levitation of a superconducting disk on top of a static magnetic field due to expulsion of the magnetic field from the superconductor.. This is also known as the Meissner effect (figure courtesy of Wikimedia).

5.3 Instantaneous Poynting's Theorem

Before we proceed further with studying energy and power, it is habitual to add fictitious magnetic current \mathbf{M} and fictitious magnetic charge ρ_m to Maxwell's equations to make them symmetric mathematically.² To this end, we have

$$\nabla \times \mathbf{E} = -\frac{\partial \mathbf{B}}{\partial t} - \mathbf{M} \quad (5.3.1)$$

$$\nabla \times \mathbf{H} = \frac{\partial \mathbf{D}}{\partial t} + \mathbf{J} \quad (5.3.2)$$

$$\nabla \cdot \mathbf{D} = \rho \quad (5.3.3)$$

$$\nabla \cdot \mathbf{B} = \rho_m \quad (5.3.4)$$

Consider the first two of Maxwell's equations where fictitious magnetic current is included and that the medium is isotropic such that $\mathbf{B} = \mu \mathbf{H}$ and $\mathbf{D} = \epsilon \mathbf{E}$. Next, we need to consider only the first two equations (since in electrodynamics, by invoking charge conservation, the third and the fourth equations are derivable from the first two). They are

$$\nabla \times \mathbf{E} = -\frac{\partial \mathbf{B}}{\partial t} - \mathbf{M}_i = -\mu \frac{\partial \mathbf{H}}{\partial t} - \mathbf{M}_i \quad (5.3.5)$$

$$\nabla \times \mathbf{H} = \frac{\partial \mathbf{D}}{\partial t} + \mathbf{J} = \epsilon \frac{\partial \mathbf{E}}{\partial t} + \mathbf{J}_i + \sigma \mathbf{E} \quad (5.3.6)$$

where \mathbf{M}_i and \mathbf{J}_i are impressed current sources. They are sources that are impressed into the system, and they cannot be changed by their interaction with the environment [50].

Also, for a conductive medium, a conduction current or induced current flows in addition to impressed current. Here, $\mathbf{J} = \sigma \mathbf{E}$ is the induced current source in the conductor. Moreover, $\mathbf{J} = \sigma \mathbf{E}$ is similar to ohm's law. We can show from By dot multiplying (5.3.5) with \mathbf{H} , and

²Even though magnetic current does not exist, electric current can be engineered to look like magnetic current as shall be learnt.

dot multiplying (5.3.6) with \mathbf{E} , we can show that

$$\mathbf{H} \cdot \nabla \times \mathbf{E} = -\mu \mathbf{H} \cdot \frac{\partial \mathbf{H}}{\partial t} - \mathbf{H} \cdot \mathbf{M}_i \quad (5.3.7)$$

$$\mathbf{E} \cdot \nabla \times \mathbf{H} = \varepsilon \mathbf{E} \cdot \frac{\partial \mathbf{E}}{\partial t} + \mathbf{E} \cdot \mathbf{J}_i + \sigma \mathbf{E} \cdot \mathbf{E} \quad (5.3.8)$$

Using the identity, which is the same as the product rule for derivatives, we have³

$$\nabla \cdot (\mathbf{E} \times \mathbf{H}) = \mathbf{H} \cdot (\nabla \times \mathbf{E}) - \mathbf{E} \cdot (\nabla \times \mathbf{H}) \quad (5.3.9)$$

Therefore, from (5.3.7), (5.3.8), and (5.3.9) we have

$$\nabla \cdot (\mathbf{E} \times \mathbf{H}) = - \left(\mu \mathbf{H} \cdot \frac{\partial \mathbf{H}}{\partial t} + \varepsilon \mathbf{E} \cdot \frac{\partial \mathbf{E}}{\partial t} + \sigma \mathbf{E} \cdot \mathbf{E} + \mathbf{H} \cdot \mathbf{M}_i + \mathbf{E} \cdot \mathbf{J}_i \right) \quad (5.3.10)$$

To elucidate the physical meaning of the above, we first consider $\sigma = 0$, and $\mathbf{M}_i = \mathbf{J}_i = 0$, or the absence of conductive loss and the impressed current sources. Then the above becomes

$$\nabla \cdot (\mathbf{E} \times \mathbf{H}) = - \left(\mu \mathbf{H} \cdot \frac{\partial \mathbf{H}}{\partial t} + \varepsilon \mathbf{E} \cdot \frac{\partial \mathbf{E}}{\partial t} \right) \quad (5.3.11)$$

Rewriting each term on the right-hand side of the above, we have

$$\mu \mathbf{H} \cdot \frac{\partial \mathbf{H}}{\partial t} = \frac{1}{2} \mu \frac{\partial}{\partial t} \mathbf{H} \cdot \mathbf{H} = \frac{\partial}{\partial t} \left(\frac{1}{2} \mu |\mathbf{H}|^2 \right) = \frac{\partial}{\partial t} W_m \quad (5.3.12)$$

$$\varepsilon \mathbf{E} \cdot \frac{\partial \mathbf{E}}{\partial t} = \frac{1}{2} \varepsilon \frac{\partial}{\partial t} \mathbf{E} \cdot \mathbf{E} = \frac{\partial}{\partial t} \left(\frac{1}{2} \varepsilon |\mathbf{E}|^2 \right) = \frac{\partial}{\partial t} W_e \quad (5.3.13)$$

where $|\mathbf{H}(\mathbf{r}, t)|^2 = \mathbf{H}(\mathbf{r}, t) \cdot \mathbf{H}(\mathbf{r}, t)$, and $|\mathbf{E}(\mathbf{r}, t)|^2 = \mathbf{E}(\mathbf{r}, t) \cdot \mathbf{E}(\mathbf{r}, t)$. Then (5.3.11) becomes

$$\nabla \cdot (\mathbf{E} \times \mathbf{H}) = - \frac{\partial}{\partial t} (W_m + W_e) \quad (5.3.14)$$

where

$$W_m = \frac{1}{2} \mu |\mathbf{H}|^2, \quad W_e = \frac{1}{2} \varepsilon |\mathbf{E}|^2 \quad (5.3.15)$$

Equation (5.3.14) is reminiscent of the current continuity equation, namely that,

$$\nabla \cdot \mathbf{J} = - \frac{\partial \rho}{\partial t} \quad (5.3.16)$$

which is a statement of charge conservation. In other words, time variation of current density at a point is due to charge density flow into or out of the point.

The vector quantity

$$\mathbf{S}_p = \mathbf{E} \times \mathbf{H} \quad (5.3.17)$$

³The cyclical identity that $\mathbf{a} \cdot (\mathbf{b} \times \mathbf{c}) = \mathbf{c} \cdot (\mathbf{a} \times \mathbf{b}) = \mathbf{b} \cdot (\mathbf{c} \times \mathbf{a})$ is useful for the derivation.

is called the Poynting's vector, and (5.3.14) becomes

$$\nabla \cdot \mathbf{S}_p = -\frac{\partial}{\partial t} W_t \quad (5.3.18)$$

where $W_t = W_e + W_m$ is the total energy density stored in the electric and magnetic fields. The above is similar to the current continuity equation in physical interpretation mentioned above. Analogous to that current density is charge density flow, power density is energy density flow. It is easy to show that \mathbf{S}_p has a dimension of watts per meter square, or power density, and that W_t has a dimension of joules per meter cube, or energy density.

Now, if we let $\sigma \neq 0$, then the term to be included is then $\sigma \mathbf{E} \cdot \mathbf{E} = \sigma |\mathbf{E}|^2$ which has the unit of S m^{-1} times $\text{V}^2 \text{ m}^{-2}$, or W m^{-3} where S is siemens. We arrive at this unit by noticing that $\frac{1}{2} \frac{V^2}{R}$ is the power dissipated in a resistor of R ohms with a unit of watts. The reciprocal unit of ohms, which used to be called mhos is now called siemens. With $\sigma \neq 0$, (5.3.18) becomes

$$\nabla \cdot \mathbf{S}_p = -\frac{\partial}{\partial t} W_t - \sigma |\mathbf{E}|^2 = -\frac{\partial}{\partial t} W_t - P_d \quad (5.3.19)$$

Here, $\nabla \cdot \mathbf{S}_p$ has physical meaning of power density oozing out from a point, and $-P_d = -\sigma |\mathbf{E}|^2$ has the physical meaning of power density dissipated (siphoned) at a point by the conductive loss in the medium which is proportional to $-\sigma |\mathbf{E}|^2$.

Now if we set \mathbf{J}_i and \mathbf{M}_i to be nonzero, (5.3.19) is augmented by the last two terms in (5.3.10), or

$$\nabla \cdot \mathbf{S}_p = -\frac{\partial}{\partial t} W_t - P_d - \mathbf{H} \cdot \mathbf{M}_i - \mathbf{E} \cdot \mathbf{J}_i \quad (5.3.20)$$

The last two terms can be interpreted as the power density supplied by the impressed currents \mathbf{M}_i and \mathbf{J}_i . Therefore, (5.3.20) becomes

$$\nabla \cdot \mathbf{S}_p = -\frac{\partial}{\partial t} W_t - P_d + P_s \quad (5.3.21)$$

where

$$P_s = -\mathbf{H} \cdot \mathbf{M}_i - \mathbf{E} \cdot \mathbf{J}_i \quad (5.3.22)$$

Here, P_s is the power supplied by the impressed current sources. These terms are positive if \mathbf{H} and \mathbf{M}_i have opposite signs, or if \mathbf{E} and \mathbf{J}_i have opposite signs. The last terms reminds us of what happens in a negative resistance device or a battery.⁴ In a battery, positive charges move from a region of lower potential to a region of higher potential (see Figure 5.7). The positive charges move from one end of a battery to the other end of the battery. Hence, they are doing an "uphill climb" driven by chemical processes within the battery.

⁴A negative resistance has been made by Leo Esaki [51], winning him a share in the Nobel prize.

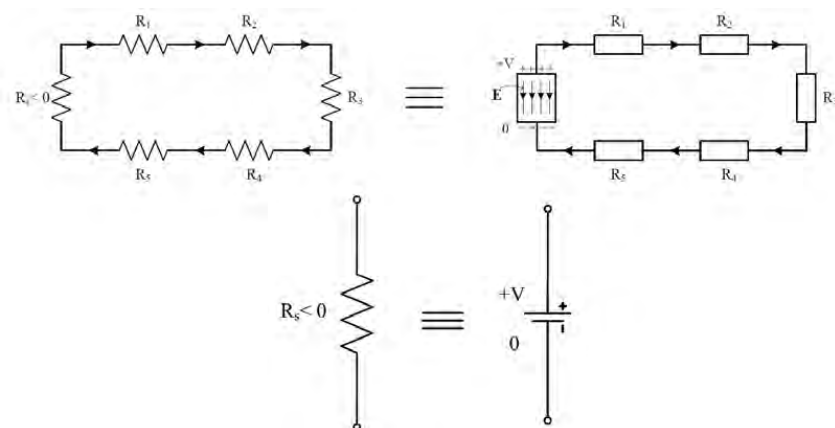

Figure 5.7: Figure showing the dissipation of energy as the current flows around a loop. A battery can be viewed as having a negative resistance.

In the above, one can easily work out that P_s has the unit of $W m^{-3}$ which is power supplied density. One can also choose to rewrite (5.3.21) in integral form by integrating it over a volume V and invoking the divergence theorem yielding

$$\int_S d\mathbf{S} \cdot \mathbf{S}_p = -\frac{d}{dt} \int_V W_t dV - \int_V P_d dV + \int_V P_s dV \quad (5.3.23)$$

The left-hand side is

$$\int_S d\mathbf{S} \cdot \mathbf{S}_p = \int_S d\mathbf{S} \cdot (\mathbf{E} \times \mathbf{H}) \quad (5.3.24)$$

which represents the power flowing out of the surface S .

